

Method 5 – Isokinetic Metering Console



Part # 0028

**User Manual
May, 2008**



Questions? Contact us at 800-223-3977 or online at
<http://www.cleanair.com/equipment/Express/main.html>

Console Serial Number _____

IMPORTANT!!!.....	1
Customer Feedback	2
1 Safety.....	3
1.1 Weight and Bulk	3
1.2 Pump Cleaning	3
1.3 Electrical Shock	3
2 Principles of Operation	4
2.1 Gases Analyzed	4
2.2 System Components	5
2.3 System Operation.....	7
2.3.1 Description of Controls	7
2.3.2 Meter Control Console Initial Set-up	9
2.3.3 Modular Sample Unit.....	10
3 Routine Maintenance and Inspection	11
3.1 Pump Maintenance.....	11
3.1.1 Pump Assembly Definitions.....	11
3.1.2 Preventative Maintenance.....	12
3.1.3 Six month maintenance.....	13
3.2 Maintenance Outside the Pump	15
3.3 Other Maintenance Issues.....	15
4 Troubleshooting	16

IMPORTANT!!!

BEFORE YOU BEGIN READ THIS!!!



READ AND UNDERSTAND ALL INSTRUCTIONS BEFORE USING THIS SYSTEM!

SAVE THESE INSTRUCTIONS!!!

- **To Avoid Accidents...**
 - ✓ Keep your work area clean and well lit.
 - ✓ Keep bystanders away.
 - ✓ Exercise common sense.
- **Electrical Safety...**
 - ✓ Do not operate in combustible environments.
 - ✓ DO NOT operate these products when wet or in water.
 - ✓ ALWAYS be sure that the components of this system are running with the correct voltage (120V).
 - ✓ Never remove a grounding prong or modify a plug.
 - ✓ Do not abuse the power cord or plug.
- **Personal Safety...**
 - ✓ The parts of this system are heated in excess of 500 degrees Fahrenheit. Use caution when handling your equipment during and after a test.
 - ✓ Stay alert and watch what you are doing.
 - ✓ Dress appropriately. Wear the appropriate personal safety devices.
- **Equipment Maintenance...**
 - ✓ Clean Air Express can not ensure that our Method 5 meter is compatible with any other systems. See <http://www.cleanair.com> or call (800) 223-3977 for more information.
 - ✓ Maintenance and repairs should be performed by one of Clean Air Express's trained technicians.

Customer Feedback

Clean Air Engineering takes pride in our quality products and services. We strive to provide the highest quality products and services in the industry. We realize the importance of end user input in the continual improvement of our products and services. Customer feedback is of paramount importance. **We encourage your feedback with any suggestions or problems that can help us improve our performance.** A customer feedback form is available online at <http://www.cleanair.com/About/feedback.html>. To emphasize our commitment to quality products and complete customer satisfaction, Clean Air Engineering's manufacturing division, CAE Express, offers what we feel is the best and most comprehensive warranty in the environmental industry.

1 Safety

Safety should always be considered first, and proper safety procedures should be followed.

1.1 Weight and Bulk

The Isokinetic Control Console weighs approximately 70 pounds (32 kg) and has dimensions of 17.5" x 12" x 27" (445mm x 305mm x 686mm). It includes handles to make the system easier to lift and carry. However, remember to use good lifting technique in order to avoid injury. Two persons should be utilized if necessary. Do **not** attempt to carry the weight yourself if you do not feel comfortable doing so.

1.2 Pump Cleaning

When flushing the pump, a **nonflammable** flushing solvent should be used.

 **WARNING!!** Do **NOT** use kerosene, gasoline or any other flammable liquid to flush the pump!! Harmful vapors can result in personal injury or damage to the pump itself.

1.3 Electrical Shock

The system is powered by a standard 120 VAC line, meaning potentially fatal shocks are possible. It is no more dangerous than many household appliances in this regard; however, care must be taken to avoid shock. Before performing any maintenance or removing the back cover, **turn off** and **unplug the console** from the 120 VAC line. Be sure that the correct voltage is used in order to help prevent accidents.



2 Principles of Operation

The Isokinetic Control Console is designed to sample a gas stream. The system should be set up to extract the sample at the same rate that the gas flows from the stack. The gases are extracted through a probe and then through a heated filter chamber where a majority of the particulate is removed. The hot gases then travel through a series of chilled impingers where condensates are removed and the gases are cooled and dried before pumping. This console is suitable for EPA methods 4, 5, 5I, 6, 8, 8A, 13, 17, 23, 26, 29, and many more (with proper accessories). Access to the wiring and other components of the control box is achieved by removing the back panel of the unit. Access to the pump box is gained by removing the front panel.

2.1 Gases Analyzed

- Method 4 – Water vapor content
- Method 5 – Particulate matter
- Method 6 – Sulfur Dioxide
- Method 8 – Sulfuric Acid Mist
- Method 13 - Fluoride
- Method 17 – In stack particulate
- Method 23 – Dioxin and Furan
- Method 26 – Halides and Halogens
- Method 29 – Metals Emissions

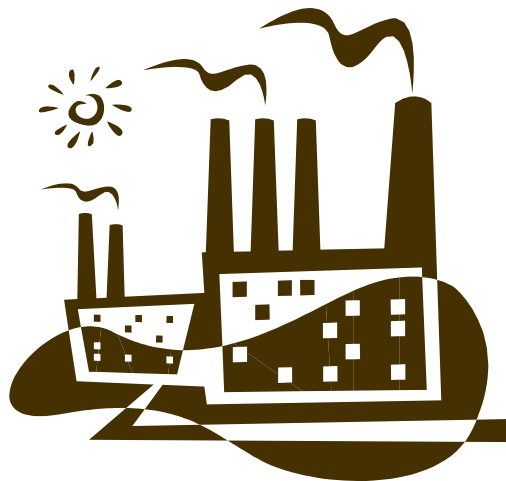

2.2 System Components

Requires 120 V. See [Figure 1](#) on the following page.

- (1) – Dual 8” incline manometer
- (2) – Manometer leveling wheel
- (3) – Circuit breaker switches
- (4) - Timer
- (5) – Dry gas meter index
- (6) – 6 channel temperature indicator
- (7) – Temperature controllers for probe and filter
- (8) – Thermocouple plug input bank
- (9) – Power connections
- (10) – Umbilical Amphenol connection
- (11) – Vacuum pump connections
- (12) – Pitot tube connections
- (13) – Umbilical connection
- (14) – Vacuum gauge
- (15) – Fine flow adjustment knob
- (16) – Coarse flow adjustment knob Power connections
- (17) – IGS rotometer
- (18) – IGS sample connection
- (19) – Flow clamp (positive leak check tube)
- (20) – Power cord

Figure 1

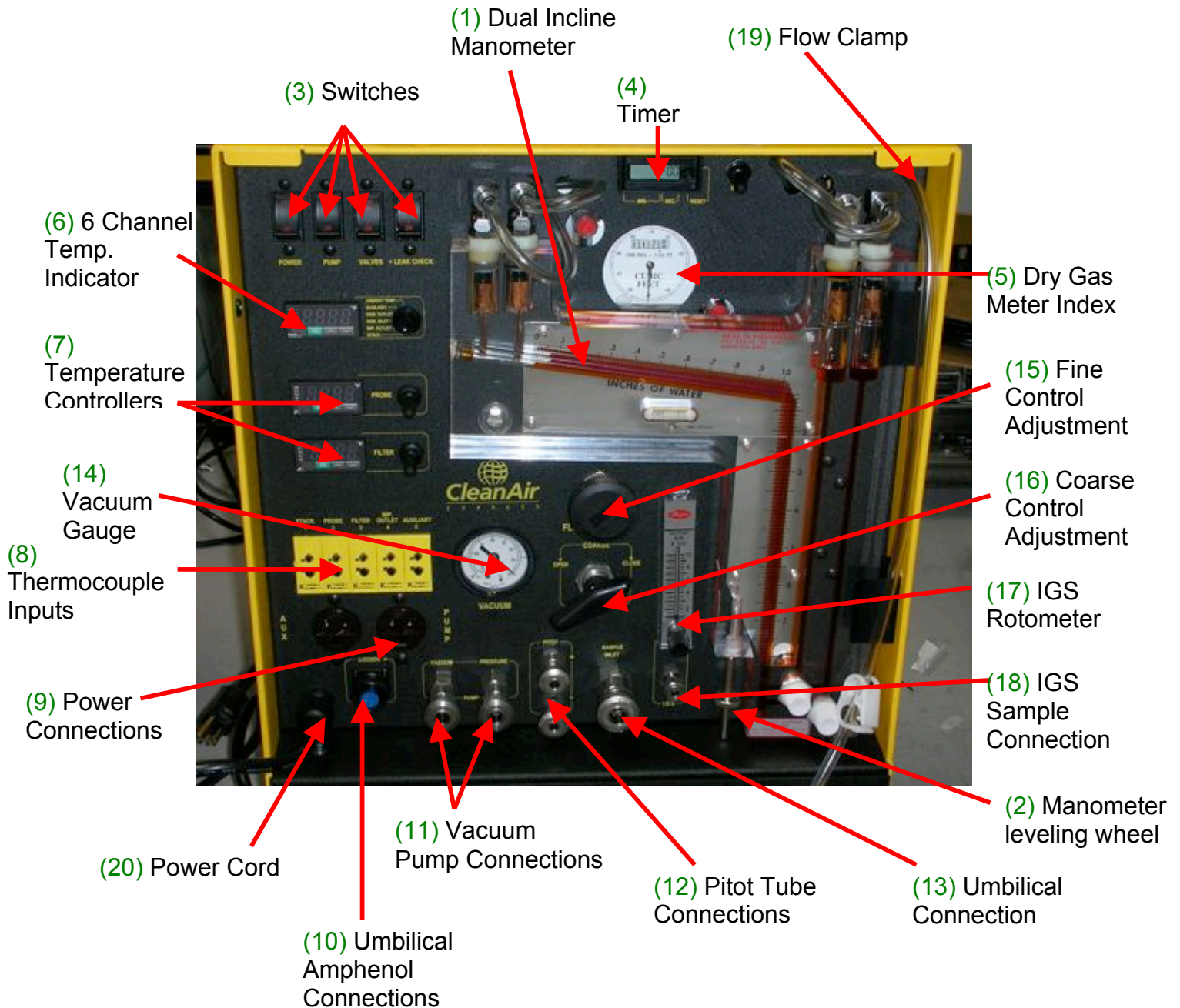

2.3 System Operation

2.3.1 Description of Controls

- **AC Power Connections (9):** transfer power to the vacuum pump and an auxiliary device.

NOTE: The vacuum pump must be connected to the “pump” outlet

- **Amphenol Connection (10):** provides power to the probe heater and filter oven
- **Coarse Control Adjustment (16):** opens and closes the sample line
- **Dry Gas Meter (5):** displays the volume of gas flowing through the internal diaphragm pump; one revolution equal 0.1 cubic feet of gas. The index indicator accumulates and displays the total gas volume. (see **Figure 2**)
- **Fine Control Adjustment (15):** When coarse control is open, this is used to fine-tune the gas flow rate through the system. Turn clockwise to open.
- **IGS Collection (18):** sample collection system designed to simultaneously collect a representative gas sample for the analysis of O₂, CO₂, and CO. Connect the sample collection bag to the ¼” fitting beneath the flow meter and adjust to the desired setting.

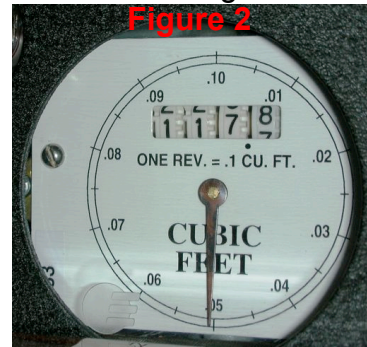

WARNING!!! The IGS system works off the orifice exhaust. Some agencies may not allow this type of sampling for compliance testing.

- **Temperature Indicator (6):** displays the temperature of each point on the selector switch.
- **Manometer (1):** indicates the DP (red oil) and DH (yellow oil). The DP gauge measures the differential stack pressure, from 0” to 8” of water, via the S-Type Pitot tube from the probe. The DH gauge measures the pressure drop across the outlet side of the dry gas meter.
- **Pitot Line Connections (12):** the connections to the positive and negative side of the Pitot tube lines in the umbilical cable assembly. Be certain to match the sample probe positive and negative with the meter console’s positive and negative.

- **Switches (3):**
 - *Power Switch:* The 15 Amp double pole circuit breaker switch, provides power to the control unit
 - *Pump Switch:* the 10 Amp circuit breaker switch, provides power to the vacuum pump
 - *Valve Switch:* Activates the solenoid that bypasses the DH column on the incline manometer. Useful for zeroing DH while running the pump. At high flow rates the switch will help prevent oil from discharging from the manometer.
 - *Leak Check Switch:* Activates solenoid that makes it possible to leak check the positive side of the meter console. To perform a leak check do the following
 - 1.) **Unplug the unit.** Remove rear door.
 - 2.) Slide copper elbow off of the orifice and plug orifice with the rubber stopper supplied.
 - 3.) Plug the unit in. Turn the main power switch (3) on.
 - 4.) Turn the valve switch (3) 'off' and the leak check switch (3) 'on.'
 - 5.) **Close the coarse valve (16).**
 - 6.) Remove the elbow fitting on the low side of the manometer yellow gauge oil column. Replace with the extra fitting that is provided with the unit. DO NOT attach tubing to the new fitting, its purpose is simply to vent the manometer.
 - 7.) Withdraw the tubing from the upper right hand corner of the console, a white flow clamp should be attached (19).
 - 8.) Blow into this tube to pressurize the dry gas meter. The amount of pressure is registered on the manometer yellow gauge oil column. The system should be pressurized to 17.5 cm on the manometer (1), mark this point with a piece of tape. The white flow clamp should be closed. If no leaks are present the manometer oil will remain steady. If not, leaks should be located and fixed before testing.
- **Timer (4):** displays minutes and seconds. A backup battery is provided in case of power failure. Timer will not actuate unless the timer switch is turned on.

- **Temperature Controllers (7):** The programmable temperature controllers regulate the temperature of the sampling probe and the filter assembly oven. The controllers are set to operate at 250 degrees Fahrenheit (120°C). To change this set point use the following steps: (see **Figure 3**)
 - 1.) Press the select button (3-2). 250° F will be displayed.
 - 2.) Use the up and down buttons (3-1) to change the set point
 - 3.) Re-autotune your equipment to the new set point
 - 4.) Press both the up and down controls (3-1) simultaneously until AUT appears
 - 5.) Press the select button (3-2) and hold. NO will appear
 - 6.) Press the up and select buttons (3-1, 3-2) simultaneously until YES appears. Release
 - 7.) The controller will autotune to the new set point. The display will flash TUNE
 - 8.) Autotuning is complete when the flashing stops

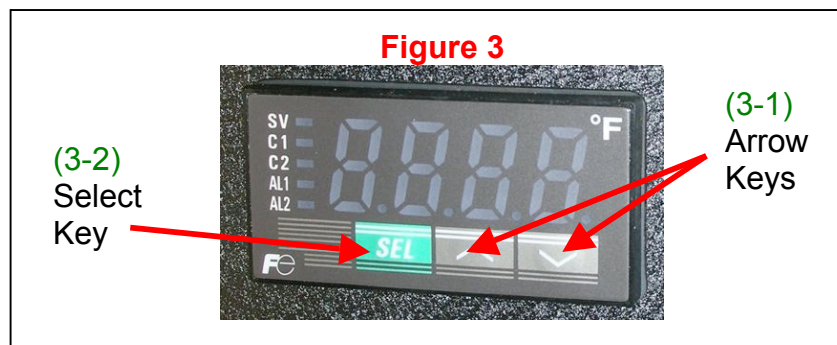

2.3.2 Meter Control Console Initial Set-up

- 1.) Locate a level surface that can support the meter box console and pump box. Adjust the manometer leveling wheel to 'zero' the manometer
- 2.) Connect the vacuum pump to the control console as follows:
 - a. Plug the male power plug into the connection marked "pump."
 - b. Connect the vacuum and pressure hoses into the fitting marked "vacuum" and "pressure." The letters "V" and "P" are stamped into the fitting of each pump hose to differentiate them. Be sure that the connections are snapped into place. To check lightly tug on the connections; they should not come apart.
- 3.) Connect the umbilical as follows:
 - a. Connect the sample line into the fitting marked "sample inlet."
 - b. Connect the Pitot Lines into the fittings marked "Pitot + and -" Be sure to match the signs.
 - c. Connect the Amphenol plug into the green 4 pin fittings.

- d. Connect the male thermocouple plugs into the thermocouple input bank. Be sure to match the descriptions.

2.3.3 Modular Sample Unit

See **Figure 4**

- 1.) Attach the probe onto the probe support arm (4-1) and tighten into place. Connect the two Pitot lines.
- 2.) Connect the sample line onto the end (or optional male fitting) of the umbilical adapter
- 3.) Connect the Amphenol cable to the green four pin socket (4-2)
- 4.) Insert the male thermocouple plug into the female socket marked “filter” (4-3)
- 5.) Connect the female thermocouple with the male plug labeled 4 (4-5) on the impinger outlet (4-4).

Figure 4 – Modular Sample Unit

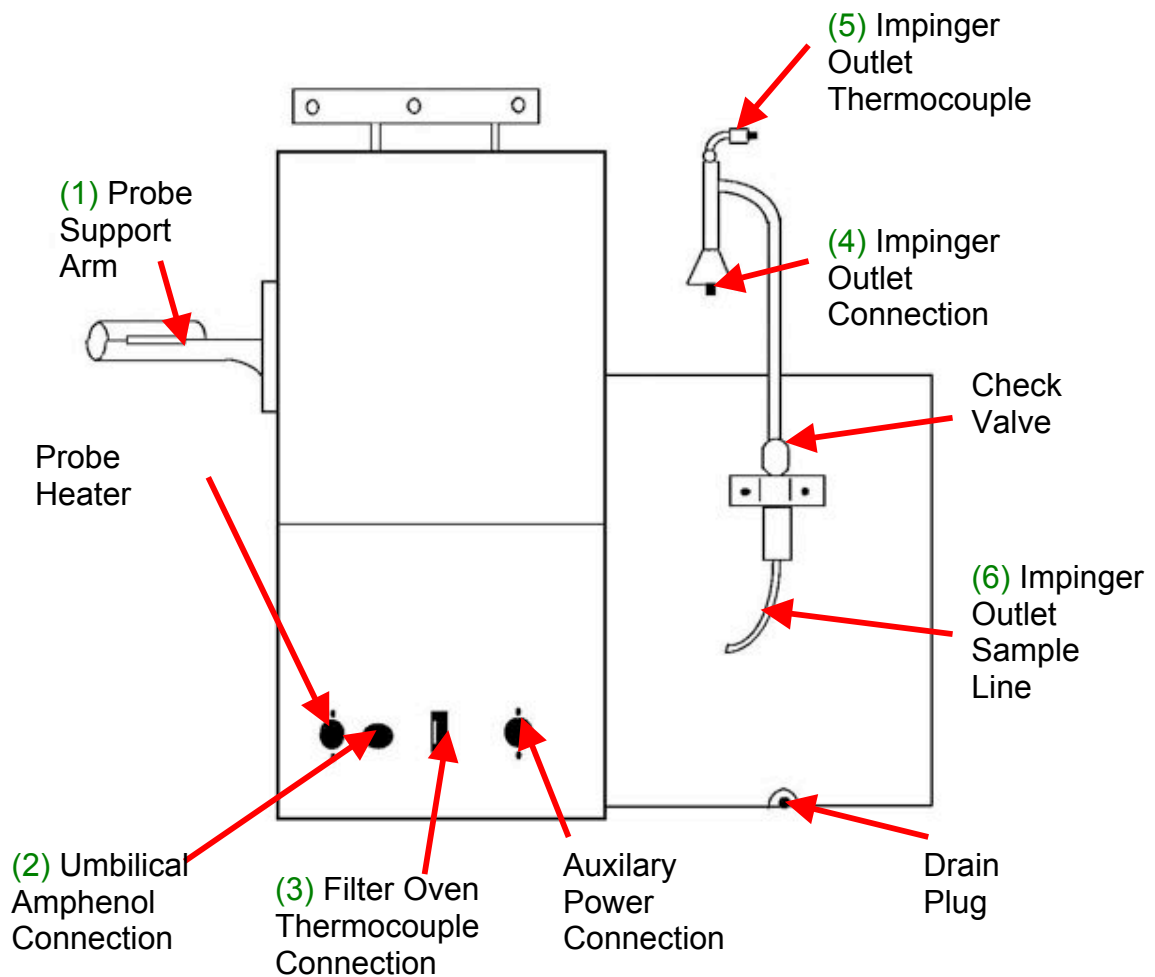

3 Routine Maintenance and Inspection

⚠ CAUTION!! – Do NOT disassemble this product outside the specifications of this manual! For internal maintenance and for the annual recalibration contact Clean Air Express.

3.1 Pump Maintenance

Materials needed:

- Gast Model no. 0523-V3 G21DX ¼ HP motor
- **Nonflammable** flushing solvent
- A 3/8 inch socket
- A 3/16 inch hex key wrench
- Brass hammer
- Spark gap feeler gage or .002” (0.05 mm) shim stock
- Teflon tape
- Clean rags
- Lubricating Oil:
 - Ambient temperatures below freezing: 5 parts SAE #10 to 1 part kerosene
 - Ambient temperatures from 32°F-100°F (0°C-38°C): SAE #10
 - Ambient temperature above 100°F (38°C)
- Replacement parts as needed

3.1.1 Pump Assembly Definitions

- **End Plate (5-3):** See **Figure 5**. Metal plate attached to the end of the pump motor with six indented hex washer ¼ - 20 screws.
- **Fittings:** Plumbing that connects the inlet and outlet jars to the body of the pump.
- **Intake Filter Assembly (5-2) (99370):** See **Figures 5 and 6**.
 - Jar **9948SJ**
 - Felt Filters (6-2) **99481 / 99482**
 - Oil Wick (6-1) **9948W**
 - Cover Gasket **9948SG**
 - Attachment Bracket
 - Brass Elbow
 - Motor Oil
- **Muffler Assembly (5-1) (9973L):** See **Figure 5**.
 - Jar **9948LJ**
 - Felt Filter **99481 / 99482**
 - Cover Gasket **9948LG**
 - Attachment Bracket and Arm

Figure 6



(6-2)
Felt
Filter

(6-1)
Oil Wick

(5-1)
Muffler
Assembly

(5-2) Intake
Filter
Assembly /
Oiler Jar

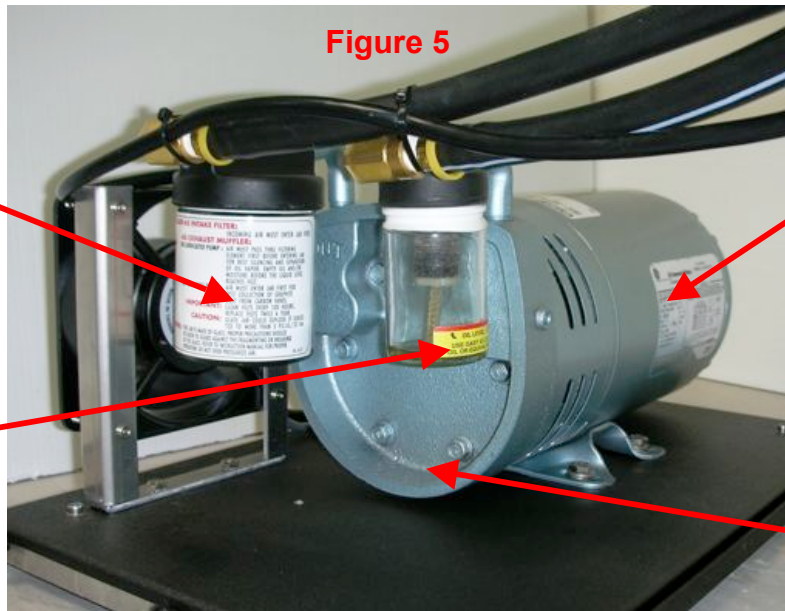

Figure 5

Pump
Motor

(5-3) End
Plate

- **Body (7-3):** See Figure 6. Metal plate that is attached to the front of the motor with two ¼ - 20 socket cap screws.
- **Rotor (7-1):** See Figure 6. Rotates and contains the four vanes.
- **Vane (7-2) (9937RV):** See Figure 6.
6. Moving pieces of molded fiber. This in conjunction with the rotor causes the vacuum action of the pump.

3.1.2 Preventative Maintenance

Periodic checks of the oil and muffler jars are mandatory. When air testing is complete the pump should be flushed with a nonflammable flushing solvent. Use the following procedure:

- **Take apart and flush the pump**
 - Remove the pump cover
 - Remove the oiler jar (5-2)
 - Remove the felt filter and oil wick
 - Connect the outlet hose to a waste container

Figure 7

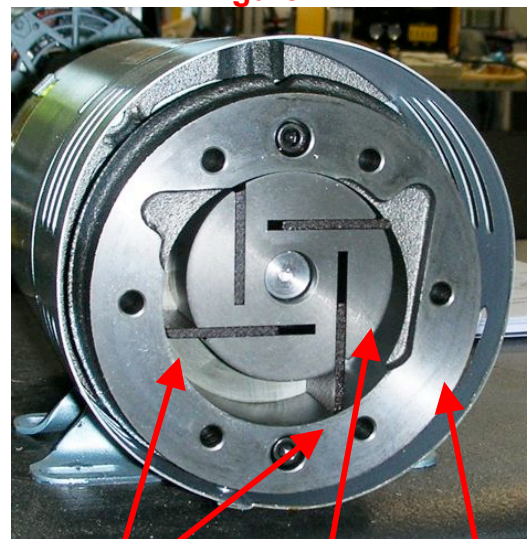

(7-2) Vanes

(7-1) Rotor

(7-3) Body

- While the pump is running squirt flushing solvent into the hole in the inlet jars cap.
- Let the pump run for 1-3 minutes or until 1 inch (25 mm) of dirty flushing solvent accumulates in the muffler jar (5-1).
- **Lubrication**
 - Squirt a small amount of clean pump oil into the inlet opening after the cleaning. Run the pump to circulate the new oil and allow any remaining solvent to evaporate
- **Reassembly**
 - Clean the oil wick and felt filter. Be sure the wick is bent slightly in the direction of the arrow on the top of the oiler jar.
 - Check and replace the cover gasket (9948SG) of the Oiler jar as needed.
 - Fill the jar to the oil line with the correct oil. To ensure a good seal put a layer of Teflon tape around the threads on the jar. Put the intake filter assembly jar back on the pump.
 - Empty and clean the muffler assembly jar.
 - Check and replace the muffler assembly jar cover gasket as needed (9948LG)
 - Clean or replace the muffler filter (99481 / 99482) and jar (9948LJ).
 - To ensure a good seal put a layer of Teflon tape around the threads on the jar.
 - Replace the pump cover.

3.1.3 Six month maintenance

- **Take apart and flush the pump**
 - Remove the pump cover
 - Remove the oiler jar (5-2)
 - Remove the felt filter and oil wick
 - Remove the muffler jar (5-1). Take out the felt filter for cleaning. Replace the jar. Clean the felt filter with flushing solvent and set aside.
 - Connect the outlet hose to a waste container
 - Tip the pump on its side.
 - While the pump is running squirt flushing solvent into the hole in the inlet jars cap.
 - Let the pump run for 1-3 minutes or until 1 inch (25 mm) of dirty flushing solvent accumulates in the muffler jar. Empty and clean the muffler jar.
 - Remove the end plate (5-3)

- **Cleaning**
 - Clean the end plate
 - Take off the pump body (7-3) and clean
 - Examine the parts for wear, replace as needed.
 - Slide the vanes (7-2) out of the rotor (7-1). Clean and replace if needed. It is recommended that if one vane needs a replacement, that they should all be replaced.
- **Lubrication**
 - When the parts are all clean or replace a thin sheet of oil is placed before reassembly.
 - Reinsert the vanes. Be sure they are properly positioned. The curved edge of the vane will be placed to match the curve of the rotor.
- **Gapping the Rotor**
 - Place the body over the rotor. Tighten the screws in such a way that the body can still be moved with light taps from a brass hammer.
 - Adjust the gap by placing a .002" (0.05mm) shim between the rotor and body. Tighten the screws
 - Turn the rotor to be sure the clearance is uniform. Make adjustments if necessary.
- **Reassembly**
 - Put the lightly oiled body back on the pump motor and tighten.
 - Inspect and check inlet and outlet fittings. Replace Teflon tape as needed.
 - Clean or replace the oil wick (6-1) and felt filter (6-2). Be sure the wick is bent slightly in the direction of the arrow on the top of the oiler jar at 3/8 of an inch.
 - Check and replace the cover gasket (9948SG) of the Oiler jar as needed.
 - Fill the jar to the oil line with the correct oil. To ensure a good seal put a layer of Teflon tape around the threads on the jar. Put the intake filter assembly jar back on the pump.
 - Empty the muffler filter assembly. Clean or replace the muffler filter (99481 / 99482) and jar (9948LJ) if necessary. The filter should be replaced after one year of weekly use.
 - Check and replace the muffler assembly jar cover gasket as needed (9948LG).
 - Let the pump run to allow any traces of flushing solvent to evaporate
 - Clean the muffler jar assembly. To ensure a good seal put a layer of Teflon tape around the threads on the jar.
 - Replace the pump cover.

3.2 Maintenance Outside the Pump

General cleanliness will extend the life of your equipment. The outside of the console can be safely cleaned with window cleaner or soapy water. Always check the inside for oil leaks, tubing damage, and wire damage. It is also recommended that the unit is returned to CleanAir Express annually for recalibration and maintenance. All tubing will be replaced (**932511**), a full electrical test will be performed, and the system will be recalibrated. Yearly recalibration is necessary.

3.3 Other Maintenance Issues

For any other maintenance issues, concerns, or questions, please contact Clean Air Express at (800)-223-3977. Clean Air Express can also be reached by mail at 212 N. Woodwork Lane Palatine, IL 60067; by fax at (847)-991-8924 or on the web at <http://www.cleanair.com/equipment/Express/main.html>



4 Troubleshooting

Problem	Possible Cause(s)	Fix
Pump motor fails to start or slows down when load is present	Tripped circuit breaker Bad wires Incorrect power Unit is too cold	Reset circuit breaker Examine wires Check for correct voltage Bring unit to room temp.
Pump stalls	Pump is dirty or foreign matter has entered the pump.	Disconnect pump's pressure and vacuum lines from the meter console. Remove pump intake filter assembly (5-2). Shoot a small amount of solvent (Carbo-sol) into the air inlet while the pump is running to flush the pump. Continue to flush until it runs freely. Squirt clean oil into the inlet to lubricate the vanes (7-2). Empty the exhaust jar of the muffler assembly (5-1). Reassemble jar assemblies
Tapping sound from pump assembly	Insufficient clearance in the pump	The pump needs to be regapped. See the six month maintenance section (page 14)
Pump motor is overheating	Too much friction due to insufficient clearance	The rotor needs to be regapped. See the six month maintenance section. An adequate substitute for a feeler gage is a piece of cellophane tape. (about .002" or .05 mm).
No oil getting to the pump for lubrication	⚠ CAUTION!! – If the pump is not properly lubricated it can cause damage to the pump. Always be sure that there is a sufficient amount of oil in the Oiler jar.	Take apart and reassemble the Oiler jar (5-2), making sure that the wick (6-1) is not too far in. Be sure there is a sufficient amount of oil. Temperature can also affect the rate of lubrication.

Problem	Possible Cause(s)	Fix
Foreign matter in the pump		Disconnect pump's pressure and vacuum lines from the meter console. Remove pump intake filter assembly (5-1). Shoot a small amount of solvent (Carbo-sol) into the air inlet while the pump is running to flush the pump. Continue to flush until it runs freely. Squirt clean oil into the inlet to lubricate the vanes (6-2). Empty the exhaust jar of the muffler assembly (5-1). Reassemble. The pump head may have to be removed in order to dispose of foreign matter.
Manometer cannot be zeroed	Not enough oil in the manometer	Add more oil to the manometer as needed (0058R., 0058Y).
Manometer rises instead of falling when pump is turned on	Pressure and vacuum hoses are most likely switched.	Check the hoses. Switch if necessary
Heated probe or filter does not warm	Bad connection Bad relay	Check all connections Replace relay (9129)

Figure 8

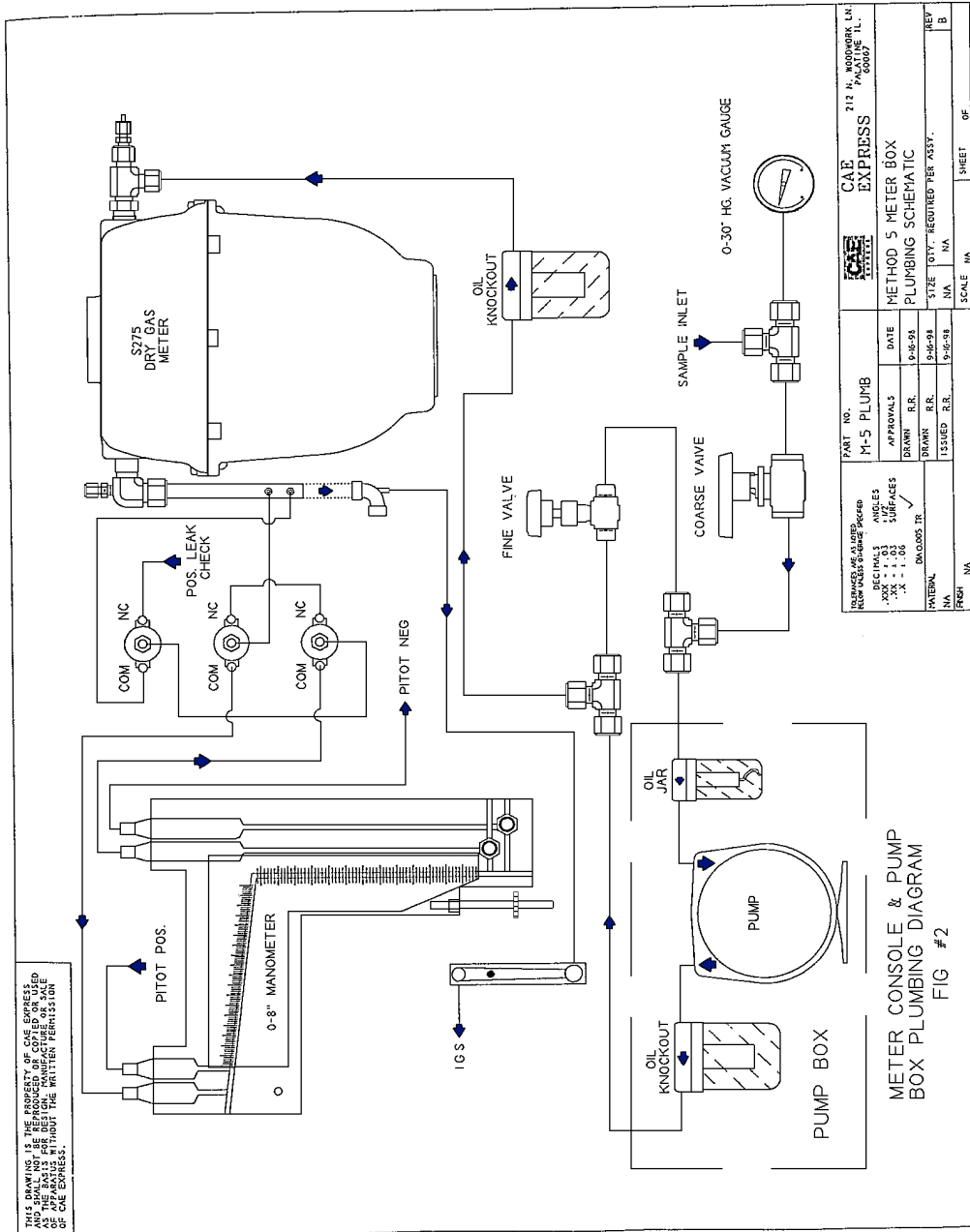
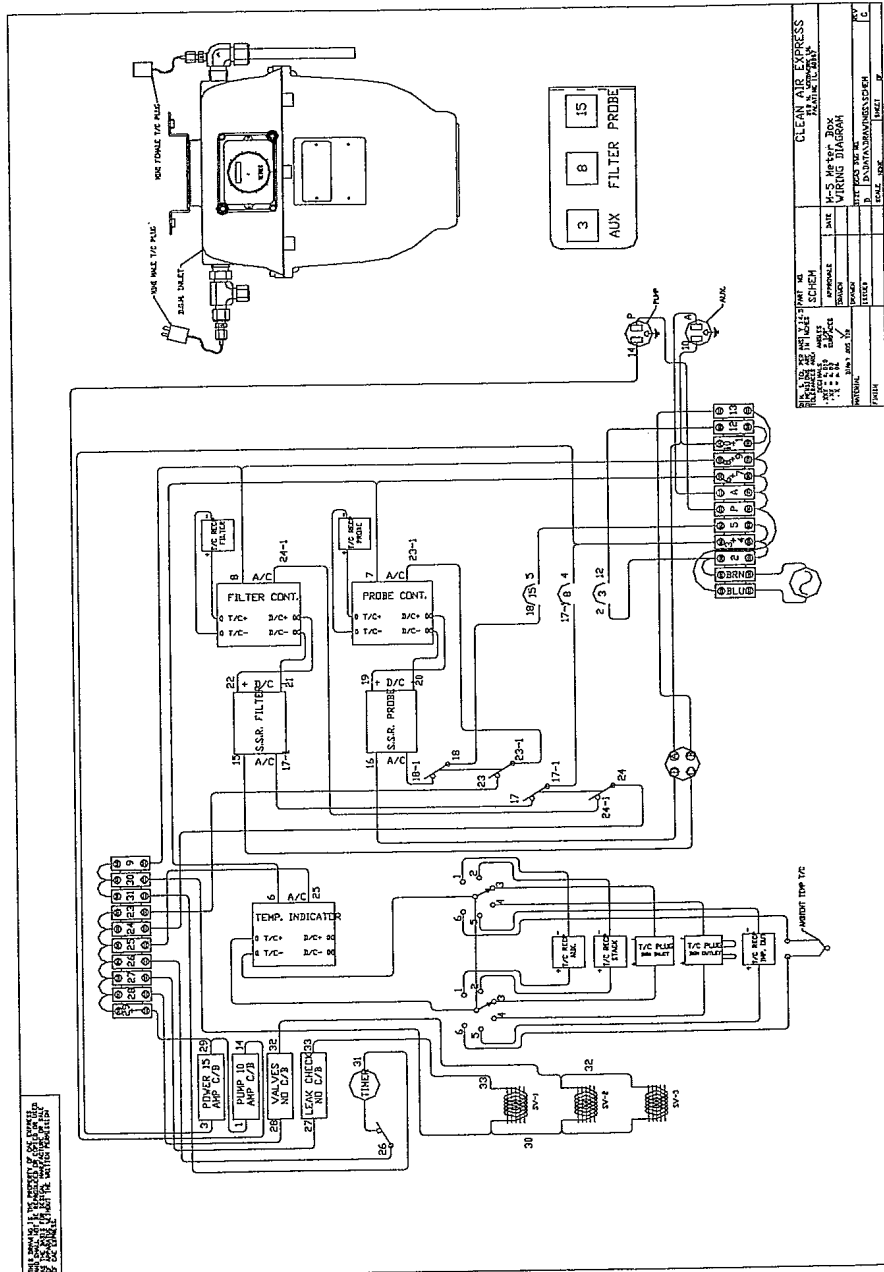

Figure 9



CLEAN AIR ENGINEERING
 PARTS LIST
 ISOKINETIC CONTROL CONSOLE
 PAGE 1

May 29, 2008

Parent Part #: 0028

Type: F

COMPONENT	DESCRIPTION	QTY	UM	TYPE
0028F	M-5 METER BOX FACE PLATE ASSEMBLY	1.0	EA	A
0028D	DRY GAS METER SUB ASSEMBLY M-5 METER BOX	1.0	EA	A
0028C	M-5 METER BOX CHASSIS (ASSY)	1.0	EA	A
0028PMP	M-5 METER BOX PUMP BOX ASSY	1.0	EA	A
0028FB	METER BOX FUSE BRACKET (SUB) ASSEMBLY	1.0	EA	A

 Sub Part #: **0028C**

M-5 Meter Box Chassis

Type: A

COMPONENT	DESCRIPTION	QTY	UM	TYPE
9512	MALE ELBOW 3/8"T-1/4" MNPT BRASS	2.0	EA	R
99312	METER BOX CHEST FRONT PANEL	1.0	EA	R
99313	METER BOX CHEST REAR PANEL	1.0	EA	R
99314	METER BOX CHEST OUTER SHELL	1.0	EA	R
9721	RUBBER GROMMET 3/8" X 1/2"	2.0	EA	R
9935	M5 METER BOX CHEST HANDLES	2.0	EA	R
9927	METER BOX HANDLE	1.0	EA	R
9948	OIL FILTER JAR BRACKET	1.0	EA	R
9946	DRAFT GAUGE BRACKET	2.0	EA	R
9924	COMPRESSING SPRING	1.0	EA	R
00588	MANOMETER 8" DUAL INCLINE	1.0	EA	R
9952	CLAMP (PINCH STYLE)	1.0	EA	R
9100M	QC MANOMETER MALE	5.0	EA	R
9100F	FEMALE QC MANOMETER	4.0	EA	R
9950	FINISHING PLUG	1.0	EA	R
9511	INSERT 3/8" OD-1/4"ID X 1/16" WALL SS	4.0	EA	R
9524	RUBBER STOPPER	1.0	EA	R
00028	MANOMETER ADJUSTMENT PLATES FOR METER BOX	1.0	EA	R
060360	60ML NALGENE BOTTLE	1.0	EA	R
99422	SERIES 50 SLIDE LATCH	4.0	EA	R

CLEAN AIR ENGINEERING
 SUMMARIZED BOM
 ISOKINETIC CONTROL CONSOLE
 PAGE 2

Sub Part #: 0028D

Type: A

Dry Gas Meter Sub Assembly

COMPONENT	DESCRIPTION	QTY	UM	TYPE
0026	I.G.S. FLOW REDUCER	1.0	EA	A
9006	CALIBRATION ORIFICE F/DRY GAS METER	1.0	EA	A
9922	DRY GAS METER S-275 ROCKWELL	1.0	EA	R
9936	SS DGM BRACKET	1.0	EA	R
9503	REDUCING BUSHING 3/4"M-3/8"FM BRASS	1.0	EA	R
9504	MALE RUN TEE 3/8"T-3/8" MNPT BRASS	1.0	EA	R
9505	TUBE END REDUCER W/NUT 3/8"T-1/8"T	1.0	EA	R
932511	3/8" OD-1/4" ID POLYETHYLENE LOW DENSITY TUBING	2.0	FT	R
9502A	DRY GAS METER THERMOCOUPLE ELBOW	1.0	EA	A
0316FM	THERMOCOUPLE PLUG MINI FEM TYPE K	1.0	EA	R
0316MM	THERMOCOUPLE PLUG MINI MALE TYPE K	1.0	EA	R

Sub Part #: 0028FB

Type: A

Meter Box Fuse Bracket

COMPONENT	DESCRIPTION	QTY	UM	TYPE
9112	CIRCUIT BREAKER 8AMP 250 VOLT	1.0	EA	R
99361	ALUMINUM FUSE BRACKET F/METER BOX	1.0	EA	R
9114	CIRCUIT BREAKER 15AMP 250 V.	1.0	EA	R
9113	CIRCUIT BREAKER 3AMP 250 VOLT	1.0	EA	R

CLEAN AIR ENGINEERING
 SUMMARIZED BOM
 ISOKINETIC CONTROL CONSOLE
 PAGE 3

Sub Part #: 0028PMP

Type: A

M-5 Meter Box Pump Box Assembly

COMPONENT	DESCRIPTION	QTY	UM	TYPE
9530	HOSE .63 DD X 3/8" ID BLACK	3.0	FT	R
9940	FAN METER PUMP BOX 115V	1.0	EA	R
9109	18 GAUGE POWER CORD 7'	1.0	EA	R
9935	M5 METER BOX CHEST HANDLES	2.0	EA	R
9143	2 CONDUCTOR WIRE	2.0	FT	R
9932	PUMP BOX ENCLOSURE	1.0	EA	R
9937	PUMP GAST METER BOX 120V/240V	1.0	EA	R
9509	QUICK CONNECT 3/8"Q-1/4" FNPT SS	2.0	EA	R
9519	PUSH LOK 1/4"-3/8" HOSE FITTING BRASS	4.0	EA	R
9520	STREET ELBOW 1/4"M-1/4"F BRASS	2.0	EA	R
9927P	PUMP HANDLE	1.0	EA	F
9932BASE	PUMP BOX BASE	1.0	EA	R
9932FRNT	PUMP BOX FRONT PANEL	1.0	EA	R
9973	FAN HOUSING BRACKET	1.0	EA	R
0016	PUMP BOX BOLTS 5/8" 1/4 20 HEX HEAD SS	4.0	EA	R
9951	BUMPER STOP	4.0	EA	R
99422	SERIES 50 SLIDE LATCH	2.0	EA	R

CLEAN AIR ENGINEERING
 SUMMARIZED BOM
 ISOKINETIC CONTROL CONSOLE
 PAGE 4

 Sub Part #: **0028F**

Type: A

M-5 Meter Box Face Plate Assembly (1)

COMPONENT	DESCRIPTION	QTY	UM	TYPE
-----	-----	-----	-----	-----
9133K	TIMER MIN/SEC WITHOUT AC/DC ADAPTER	1.0	EA	R
9325	FLEXIBLE PVC TUBING 5/16 OD X 3/16 ID 1/16 WALL CLEAR	15.0	FT	R
9418	4 PIN BOX RECEPTICLE W/FLANGE BLACK COLOR	1.0	EA	R
9127	SOLENOID VALVE 120 VOLT 3 WAY NORMALLY-CLOSED W/MTG BRACKET	3.0	EA	R
9135	30 AMP SWITCH WITHOUT CIRCUIT BREAKER	2.0	EA	R
9444DBL6	DOUBLE 6 POSITION ROTARY SWIT	1.0	EA	R
0757	FLOWMETER 100-1000CC/MIN AIR RATE-MASTER	1.0	EA	R
9141A	HUBBELL PLUG FOR OVEN COM 15 AMP 115 VAC RECEPTICLE	2.0	EA	R
9101	TERMINAL STRIP	2.0	EA	R
9515	MALE ELBOW 1/4"T-1/8" MNPTBRAS	11.0	EA	R
9139	WIRING HARNESS (M-5)METER BOX	1.0	EA	R
9133A	TIMER AC/DC ADAPTER (KAL)	1.0	EA	R
9931F	METER BOX FACE PLATE	1.0	EA	R
9939N	#6 PANEL MOUNT NUT	1.0	EA	R
9134	15 AMP CIRCUIT BREAKER SWITCH	1.0	EA	R
9136	10 AMP CIRCUIT BREAKER SWITCH	1.0	EA	R
0017	VACUUM GAUGE 30"Hg-2" U-CLAMP 1/8" FITTING	1.0	EA	R
0316PMSI	PANEL MOUNT THERMOCOUPLE	5.0	EA	R
99381	BALL VALVE SS 3/8" TUBE ENDS	1.0	EA	R
0419SNV	NEEDLE VALVE 3/8"T S.S.	1.0	EA	R
9110SR	PLASTIC POWER CORD STRAIN RELIEF AND NUT - BLACK	1.0	EA	R
0418SBU	BULKHEAD 1/4"T-1/4"T S.S.	1.0	EA	R
9507	QUICK CONNECT 3/8"Q-3/8"T UMQCSS NON VALVED	2.0	EA	R
9501	SS QUICK CONNECT 1/2"Q-1/2"T UMQC NON-VALVED	1.0	EA	R
9518	SS QUICK CONNECT 1/4"Q-1/4"T UMQCSS NON VALVED	2.0	EA	R
0028P	PLUMBING TUBE ASSY FOR METER BOX	1.0	EA	A

CLEAN AIR ENGINEERING
 SUMMARIZED BOM
 ISOKINETIC CONTROL CONSOLE
 PAGE 5

Sub Part #: 0028F

Type: A

M-5 Meter Box Face Plate Assembly (2)

COMPONENT	DESCRIPTION	QTY	UM	TYPE
9521	PORT CONNECTOR 1/4"T-3/8"F SS	1.0	EA	R
9510	PORT CONNECTOR 3/8"T-1/2"F SS	1.0	EA	R
9508B	UNION TEE 3/8" BRASS 3.0EA R			
9511	INSERT 3/8" OD-1/4"ID X 1/16" WALL SS	9.0	EA	R
9129	SOLID STATE RELAY- CRYDOM	2.0	EA	R
9103	TOGGLE SWITCH SPST 125V 15A	1.0	EA	R
9110	14 GAUGE POWER CORD 7'	1.0	EA	R
0316FM	THERMOCOUPLE PLUG MINI FEM TYPE K	1.0	EA	R
91031	TOGGLE SWITCH DPST 125V 15AMP	2.0	EA	R
91301	FUJI 32ND DIN TEMP CONTROLLER PXR3-RCY1-4VA01	3.0	EA	R
0316MM	THERMOCOUPLE PLUG MINI MALE TYPE K	1.0	EA	R
9944	THERMOCOUPLE QUICK TIP	1.0	EA	R
000021	BLACK PLASTIC CAP 1"X1/2"	1.0	EA	R
932511	3/8" OD-1/4" ID POLYETHYLENE LOW DENSITY TUBING	4.0	FT	R
99311	M5 BASE PANEL	1.0	EA	R
9951	BUMPER STOP	4.0	EA	R
9517	BARB CONNECTOR 1/4" HOSE-1/8" FNPT	1.0	EA	R

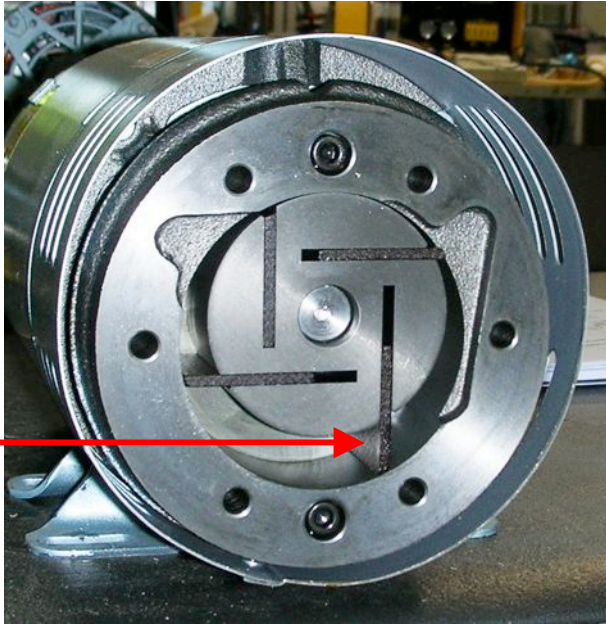

Vanes
9937RV



Oiler Jar
Cover
Gasket
9948SG

Felt Filters
99481/99482

Oiler Jar
9948SJ

Oil Wick
9948W

Pump Oil
9937O

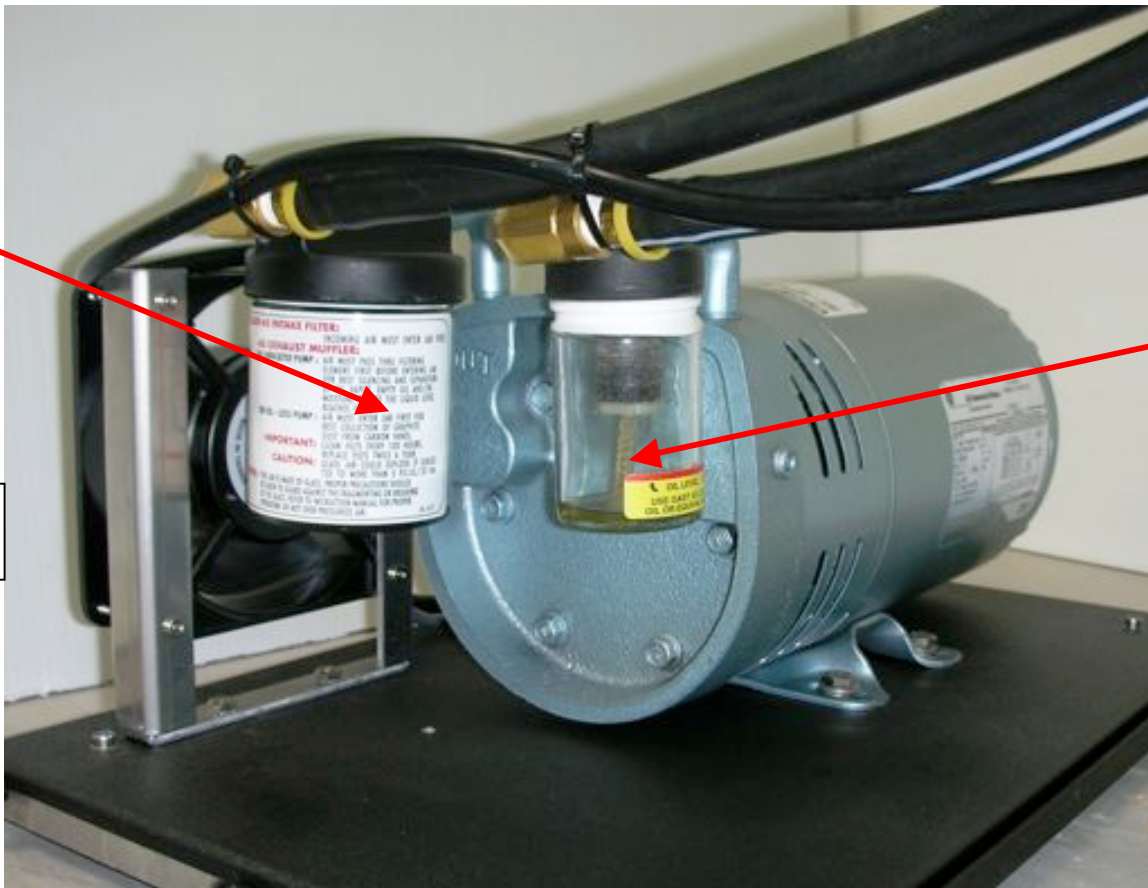

Muffler Jar
Assembly
9973L

Cover
Gasket
9948LG

Felt Filters
99481/99482

Exhaust Jar
9948LJ

Oiler Jar
Assembly
9937O

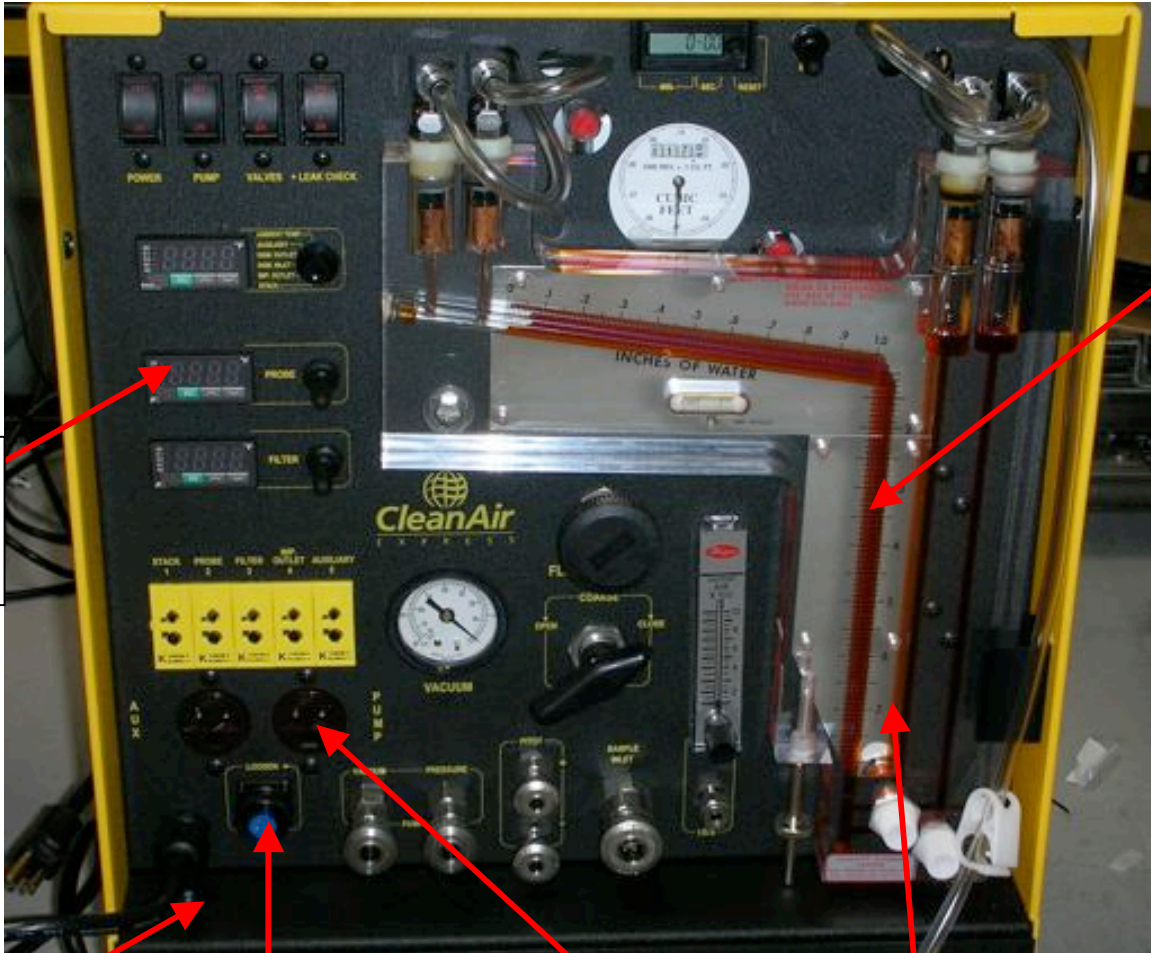

Temperature
Controllers
91301

Power
Cord
9110

Amphenol
Connection
9418

Power
Connections
9141A

Manometer Oil
0058R., 0058Y

Manometer
00588

Dry Gas Meter **9922**



Relays
9129

Clear polyethylene
tubing **932511**

Our Guarantee

Clean Air Engineering warrants products to be free from defects and workmanship for a period of one year after delivery date. The sole and exclusive remedy for defective goods shall be repair or replacement of defective parts or payment price of the goods for which damages are claimed, at Clean Air Engineering's option.

© Clean Air Engineering – June 2008